



DESIGN AND SPECIFICATIONS

SIPHONIC OUTLETS AND DRAINAGE PIPE SYSTEMS
FOR FLAT AND LOW-GRADIENT ROOFS

PIPELIFE 
always part of your life





CONTENTS

DRAINAGE SYSTEM DESIGN	4
PIPE SYSTEMS AND FITTINGS	8
FIXING TECHNOLOGY	10
APPLICATION AREAS	12
SYSTEM DESIGN SERVICE	14
PRODUCT OVERVIEW	16

DRAINAGE SYSTEM DESIGN

PIPELIFE siphonic roof drainage systems utilize negative pressure to evacuate rainwater with high flow rates. The siphonic mechanism keeps air out to produce a closed water column during drainage. Compared to gravity systems, this ensures a much higher flow velocity through smaller pipe diameters for fast and efficient drainage.

During periods of high precipitation, the siphonic apparatus draws rainwater into the downpipe at a flow rate of up to 20 l/s*. This exceeds standard siphonic drainage flow rates by up to 60% and is more than twice the flow rate of a traditional gravity system. As a result, PIPELIFE siphonic systems require far fewer outlets, downpipes and underground network connections than conventional setups.



Prefab outlets facilitate a fast and straightforward installation process.



Bespoke fittings enable installation in the majority of building types and environments.



The perfectly smooth internal pipe layer optimizes hydraulic flow and prevents debris from building up inside the system.



The system is resistant to chemical substances and micro-organisms often present in rainwater.



Transporting and storing siphonic system elements is easier and less expensive than traditional setups. The reduced number of small-diameter pipes and underground installations require less space and weight.



The system boasts a long service life of more than 50 years with minimal maintenance.

*DN75, 55 mm head of water

CONVENTIONAL SYSTEMS

VS SIPHONIC SYSTEMS

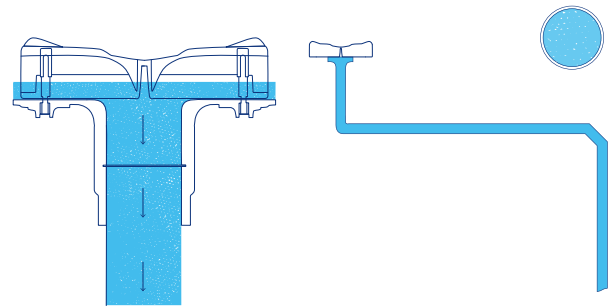
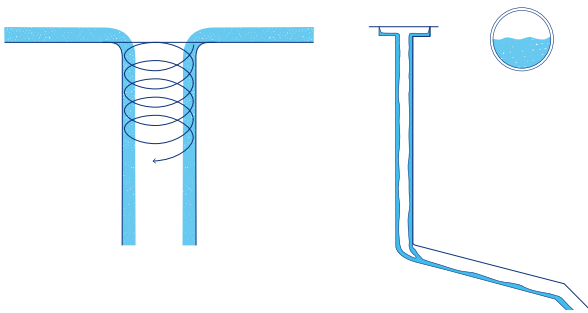
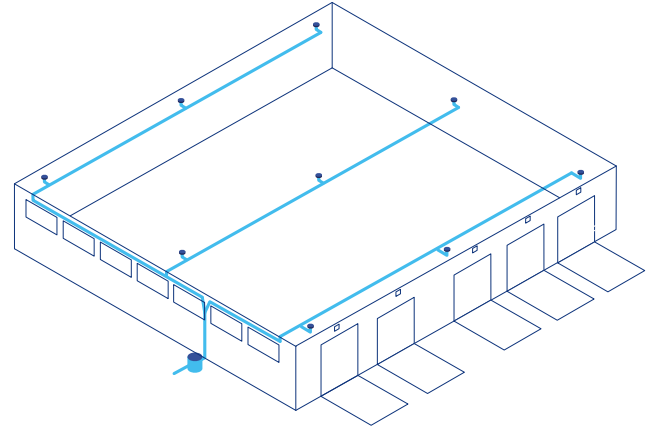
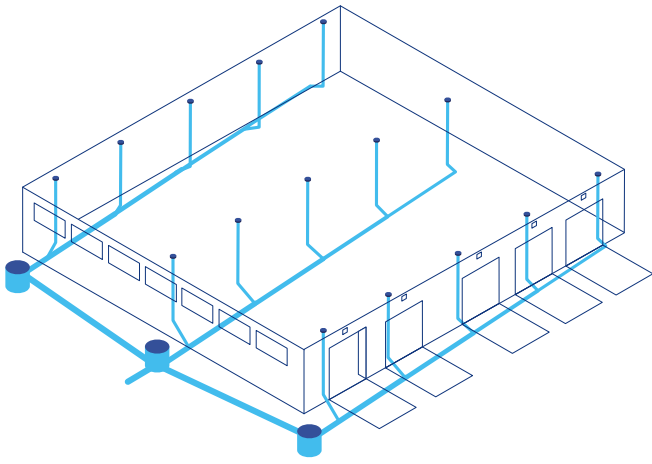

Conventional rainwater drainage systems utilize gravity to draw water into the downpipes. However, this also allows air to enter, causing the water to vortex along the pipes walls and reduce drainage flow rates.

Because rainwater can only travel along the walls of the pipe, larger pipe diameters are required, along with separate downpipes for each outlet.

Horizontal pipe sections must be installed with a slope to maintain adequate drainage throughout the system. These sections feed into downpipes that are usually connected to a large diameter collecting pipe installed underground.

Siphonic outlets utilize air baffles to prevent air from entering the pipeline and inhibit the formation of the vortex.

This ensures that the pipe's full capacity is used to transport water with negative pressure and removes the need for slopes in horizontal connecting pipes — reducing the amount of space required.

Water occupies the full inside profile of the pipe when the roof water level reaches 55 mm. By forming a closed water column, drainage flow rates throughout the system are significantly increased.

This allows for smaller pipe diameters and requires fewer pipes and underground connections overall.

SIPHONIC ROOF OUTLET

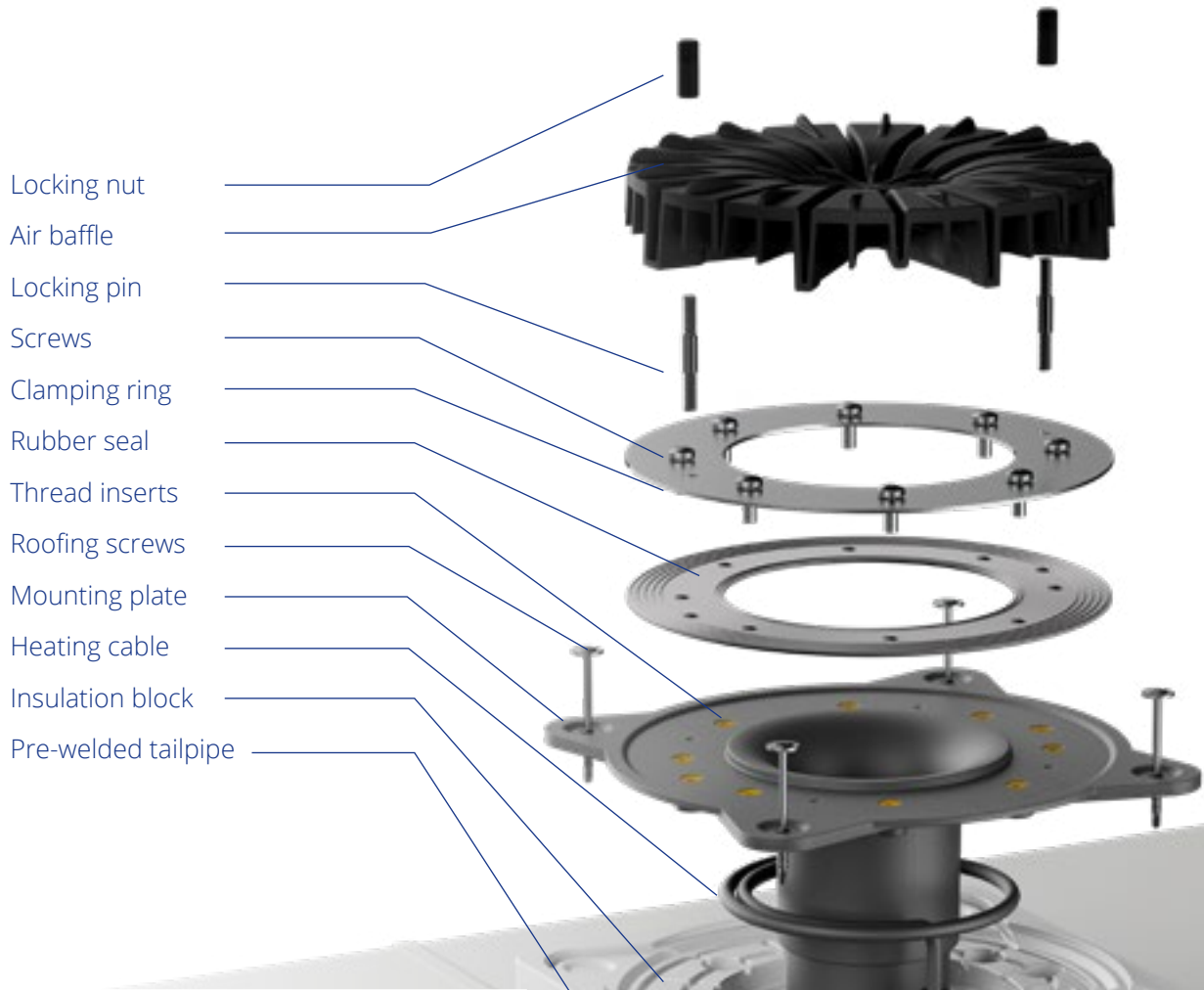

- Locking nut
- Air baffle
- Locking pin
- Screws
- Clamping ring
- Rubber seal
- Thread inserts
- Roofing screws
- Mounting plate
- Heating cable
- Insulation block
- Pre-welded tailpipe

Part	Pieces	Material
Locking nut	2	AISI304
Air baffle	1	ASA
Locking pin	2	AISI304
Screws	8	A2
Clamping ring	1	AISI304
Roofing screws	4	A2
Rubber seal	1	EPDM
Mounting plate	1	HDPE
Thread inserts	10	Brass
Insulation block	1	EPS
Heating cable	1	
Pre-welded tailpipe	1	HDPE

The siphonic outlet is crucial to the PIPELIFE flat-roof drainage system. Each outlet can drain up to 400 m² of roof surface at 20 liters per second*.

The outlet's robust top and side slots not only stop debris from entering the downpipe but also act as an air baffle that prevents vortex formation during drainage.

For straightforward maintenance, the air baffle can be installed and removed without tools. At low rain intensity, the system works like a conventional gravity system. However, during heavy rainfall (where the roof water level exceeds 55 mm), the outlet's unique design prevents air from entering the pipe, avoiding the formation of a vortex that would slow drainage flow rates.

The outlet is delivered with a pre-welded 50 cm DN75 tailpipe that can be installed on almost any roof. It is equipped with a 25 x 25 x 4 cm polystyrene insulation block that holds the outlet in position and maintains the roof's existing thermal insulation.

The seat can also host a heating cable for ice melting. The universal clamp flange offers a watertight connection to flexible insulating materials such as PVC and FPO. The clamp flange includes 8 tightening bolts and 2 thread rods. The thread rods do not require tools and come with hand fasteners for fixation to the outlet cover.



HEATING CABLE

The 10 W / 230 V self-regulating heating cable can be integrated with all outlets.

Cable length: 1 m

1. Punch a hole at the marking on the PE pipe connector.
2. Coil the cable into the screw-connected PE pipe connector.
3. Lead the excess cable length through the hole to connect to the electricity supply.

Variations of the roof outlet are available to ensure compatibility with different waterproofing layers:

- Clamp flange connection
- PVC collar for PVC-based waterproofing systems
- Bitumen collar for bitumen-based waterproofing systems
- FPO collar for FPO-based waterproofing systems
- PVB collar for PVB-based waterproofing systems (Wienerberger Leadax Roov, etc.)

*DN75, 55 mm head of water

PIPE SYSTEMS AND FITTINGS

The PIPELIFE siphonic drainage system meets the **requirements of the EN 1519-1:2019 standard** and can be used for wastewater and rainwater discharge inside buildings at a maximum temperature of 95 °C.

PIPELIFE pipes and fittings are produced from high-density polyethylene (HDPE).

The exposed air baffles are composed of an automotive-industry-standard ASA thermoplastic material that provides superior UV, abrasion and impact resistance.



PHYSICAL PROPERTIES OF HDPE

Property	Value	Measurement unit	Related standard
Density at 23°C	> 0.945	g/cm ³	EN ISO 1183-2
Melt index 190 °C / 0.5 kg	> 1.1	g/10 min	EN ISO 1133
Modulus of elasticity	1000	MPa	ICO 527-2
Tear load	22	MPa	ISO 527-2
Ultimate elongation	≥ 350	%	ISO 6259-3
Carbon-black content	≥ 2.0	%	ASTM D 1602
Thermal stability (OIT) at 200 °C	≥ 20	min	EN 728
Melt temperature of particles	≥ 130	°C	EN 728
Linear heat expansion coefficient	0.20	mm/m K	DIN 53752
Flame resistance (France)	M4	Class	NF P 92-505
Flame resistance (Germany)	B2	Class	DIN 4102 / DIN 19535-10

The diameters and wall thicknesses of PIPELIFE siphonic system pipes are indicated in the following table. These values are compliant with currently used standards.

Nominal diameter DN (mm)	External diameter OD (mm)	Minimum and maximum external diameter (mm)		Wall thickness (mm)	Series S	SDR
32	32	32	32.3	3	S 8.3	17.6
40	40	40	40.4	3		
50	50	50	50.5	3		
56	56	56	56.5	3	S 10	21
63	63	63	63.6	3		
75	75	75.5	75.7	3	S 12.5	26
90	90	90	90.9	3.5		
110	110	110	111	4.2		
125	125	125	126.2	4.8		
160	160	160	161.5	6.2		
200	200	200	201.8	6.2	S 16	33
250	250	250	252.3	7.7		
315	315	315.2	317.9	9.7		

FIXING TECHNOLOGY

The system that supports the siphonic pipework consists of the following elements:

1. Mounting rail
2. Clamp bracket
3. Threaded rod
4. Rail connection piece
5. Trapezoidal sheet hanger
6. Sliding point pipe clamp (SP)
7. Fix point pipe clamp (FP)

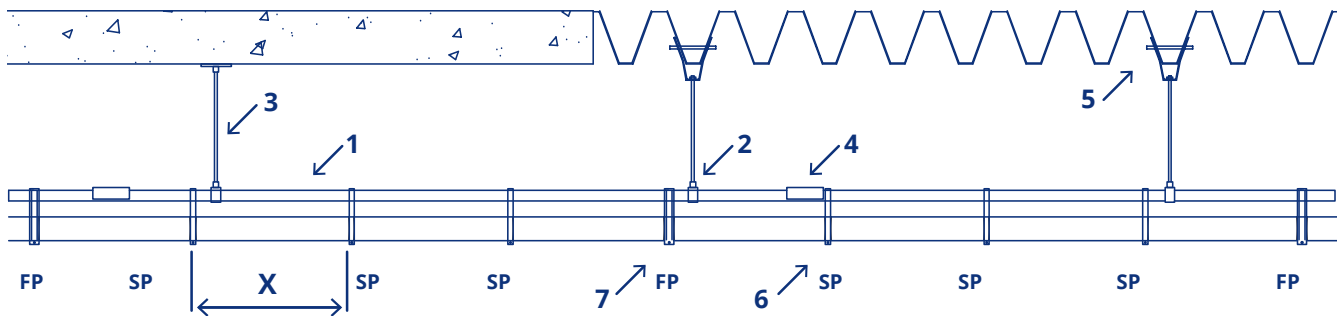

The minimum distance between mount points (X) depends on the diameter of the pipe.

Exposed horizontal pipe sections must be suspended by the support system. This system can absorb pipe elongations caused by fluctuations in temperature and consists of a C-profile rail system made from zinc-coated steel with precalculated fix points and sliding elements. It has been designed to reduce the number of suspension points, allowing for longer bridgeable distances. After preassembly on the ground level, the completed modules can be connected beneath the ceiling.

CONNECTION TYPES

PIPELIFE siphonic system pipes and fittings can be connected with the following methods:

BUTT-WELDING



ELECTRO-FUSION WELDING



Similarly to gravity systems, vertical sections are secured to the building structure using pipe clips. The system incorporates expansion sockets (compensators) between the fix points to accommodate downpipe heat expansion.

The installer must ensure that the end of the pipe's guided portion does not reach the bottom of the expansion socket.

APPLICATION OF THE EXPANSION SOCKET IN A DOWNPIPE:

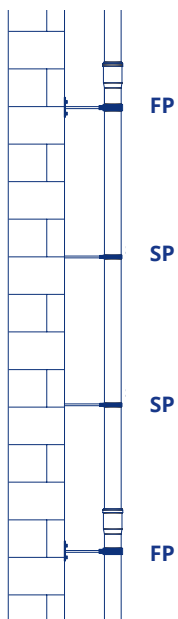

Nominal pipe diameter (mm)	Maximum distance between mounting points
40	0.8 m
50	0.8 m
56	0.8 m
63	0.8 m
75	0.8 m
90	0.9 m
110	1.1 m
125	1.2 m
160	1.6 m
200	2.0 m
250	2.5 m
315	2.5 m

Insertion depth (K) [mm] of the pipes into the expansion socket can be determined at different assembly temperatures from the table below:



DN	-10 °C	0 °C	+10 °C	+20 °C	+30 °C
40-125	147	135	123	111	99
160	150	138	126	114	102
200	191	179	167	155	143
250	185	173	161	149	137
315	205	193	181	169	157

APPLICATION AREAS

PIPELIFE's siphonic solution offers high-capacity drainage for flat roofs of up to 3% incline and a minimum area of 150 m².

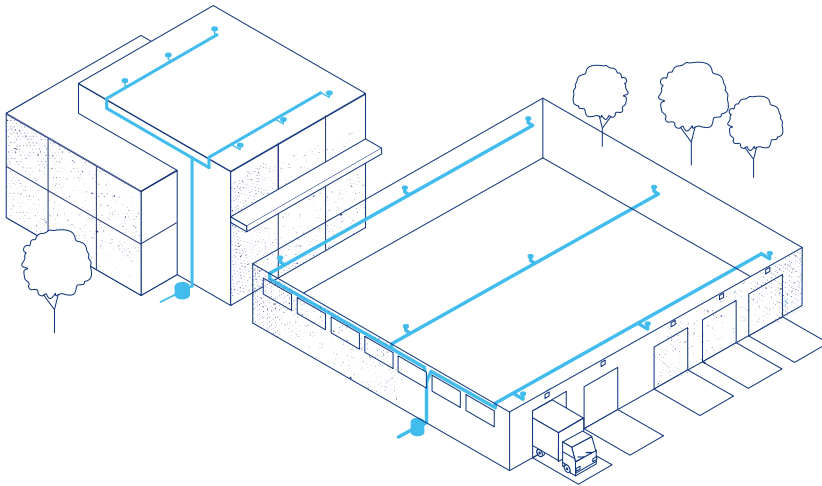

An effective choice for:

FACTORIES
WAREHOUSES
AIRPORTS
SHOPPING MALLS
CONVENTION CENTERS
APARTMENT BLOCKS
HOTELS
OFFICE BUILDINGS

 **3%**

MAXIMUM ROOF INCLINE

150 m²

MINIMUM SURFACE AREA



STANDARDS RELATED TO DESIGN
AND CONSTRUCTION

VDI 3806

DIN 1986-100

Compatible with a diverse range of roof types:

METAL ROOF

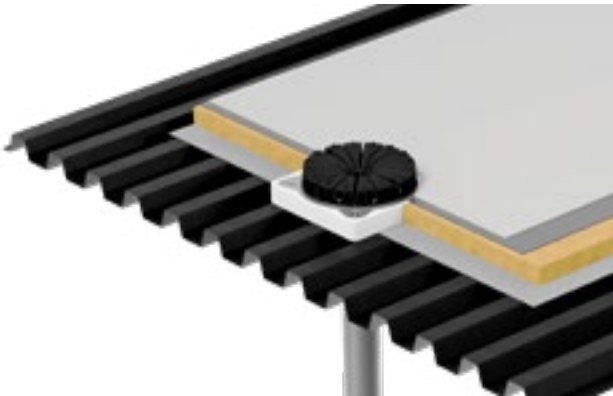

GREEN ROOF

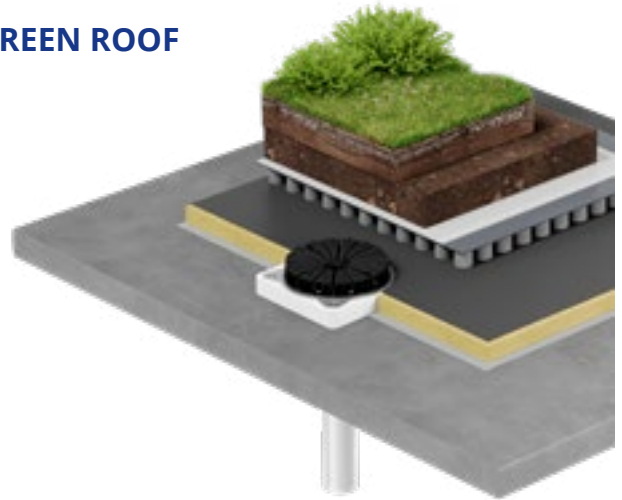

CONCRETE ROOF

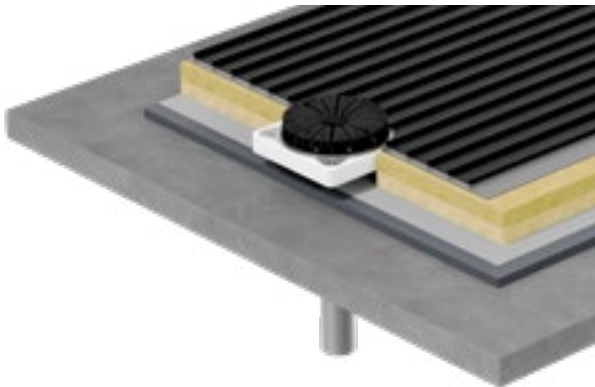

COLD ROOF

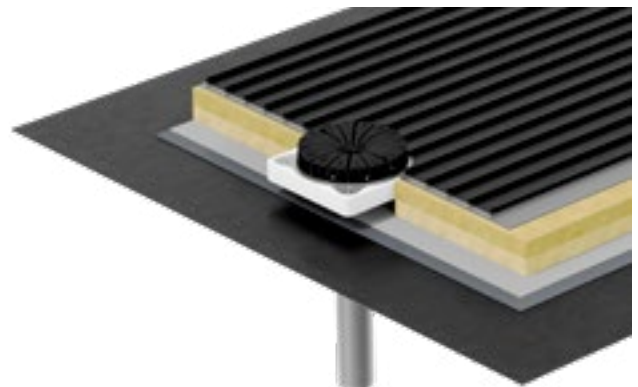

NON-WALKABLE INVERTED ROOF

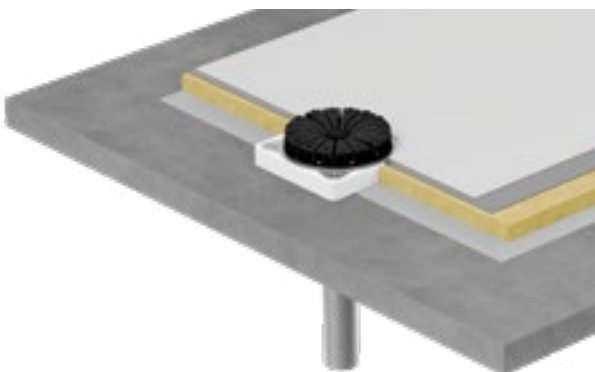

WALKABLE INVERTED ROOF

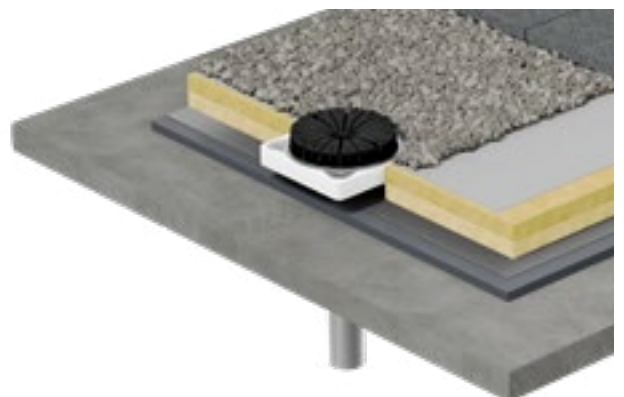

SYSTEM DESIGN SERVICE

DIMENSIONING OF HYDRAULICS

Based on information provided by the architect and building services engineer, PIPELIFE offers a hydraulic dimensioning service to identify the correct system parameters for your building.

PIPELIFE will provide all necessary documentation once dimensioning has been completed, including:

- + An isometric drawing of the system, indicating pipe diameters and mounting points
- + Quantities and specifications of required elements (pipes, fasteners, fixing devices, etc.)
- + An overall cost breakdown

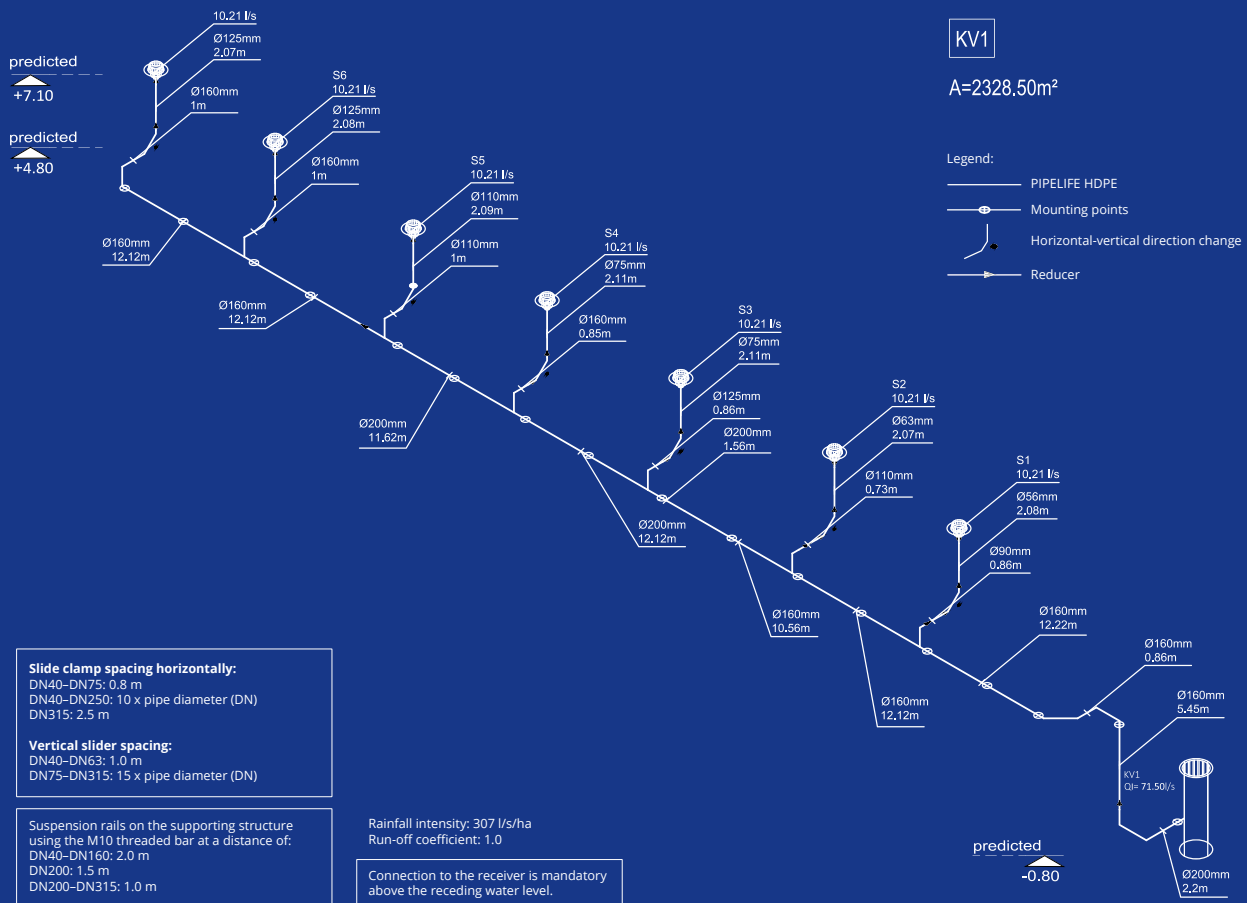

Deviations from the original documentation (e.g., changes in pipe lengths or diameters) must have written consent from PIPELIFE before being implemented.

The system's technical acceptance procedure must take place with the participation of the PIPELIFE specialists.

PIPELIFE will provide a guarantee for the siphonic drainage system based on the project supervisor's declaration.

BIM

PIPELIFE also offers a comprehensive BIM library of system assets for expert users to develop custom setups themselves.





PRODUCT OVERVIEW

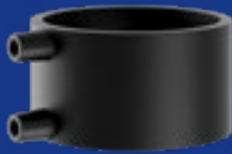
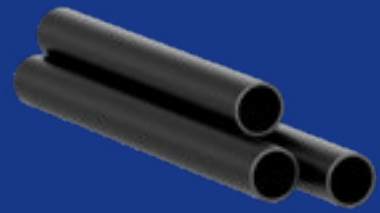

ROOF OUTLET



ARTICLE NUMBER	PRODUCT DESCRIPTION
VDPL-DN75	ROOF OUTLET DN75 WITH STEEL COMPRESSION ELEMENT
VDPL-DN75-PVC	ROOF OUTLET DN75 WITH STEEL COMPRESSION ELEMENT & PVC COLLAR
VDPL-DN75-FPO	ROOF OUTLET DN75 WITH STEEL COMPRESSION ELEMENT & FPO COLLAR
VDPL-DN75-LAD	ROOF OUTLET DN75 WITH STEEL COMPRESSION ELEMENT & LAD COLLAR

HDPE PIPES

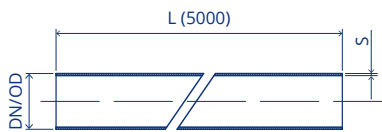

ARTICLE NUMBER	PRODUCT DESCRIPTION	DN (mm)	DI (mm)	S (mm)
VD032-5M	PIPE PEHD DN32 5M	32	26	3
VD040-5M	PIPE PEHD DN40 5M	40	34	3
VD050-5M	PIPE PEHD DN50 5M	50	44	3
VD056-5M	PIPE PEHD DN56 5M	56	50	3
VD063-5M	PIPE PEHD DN63 5M	63	57	3
VD075-5M	PIPE PEHD DN75 5M	75	69	3
VD090-5M	PIPE PEHD DN90 5M	90	83	3.5
VD110-5M	PIPE PEHD DN110 5M	110	101.4	4.3
VD125-5M	PIPE PEHD DN125 5M	125	115.2	4.9
VD160-5M	PIPE PEHD DN160 5M	160	147.6	6.2
VD200-5M	PIPE PEHD DN200 5M	200	187.6	6.2
VD250-5M	PIPE PEHD DN250 5M	250	234.4	7.8
VD315-5M	PIPE PEHD DN315 5M	315	295.4	9.8

45° BEND

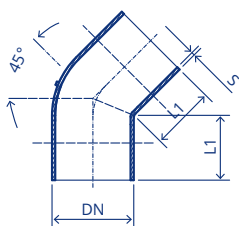

ARTICLE NUMBER	PRODUCT DESCRIPTION	DN (mm)	DI (mm)	S (mm)
1533000533	PE80 SIPH ROOF BEND 50 45° BK	50	3	48
1533000534	PE80 SIPH ROOF BEND 56 45° BK	56	3	52
1533000535	PE80 SIPH ROOF BEND 63 45° BK	63	3	52
1533000536	PE80 SIPH ROOF BEND 75 45° BK	75	3	57
1533000537	PE80 SIPH ROOF BEND 90 45° BK	90	3.5	60
1533000538	PE80 SIPH ROOF BEND 110 45° BK	110	4.2	72
1533000539	PE80 SIPH ROOF BEND 125 45° BK	125	4.8	81
1533000540	PE80 SIPH ROOF BEND 160 45° BK	160	6.2	87
1533000541	PE80 SIPH ROOF BEND 200 45° BK	200	7.2	113
1533000542	PE80 SIPH ROOF BEND 250 45° BK	250	9.1	121
1533000543	PE80 SIPH ROOF BEND 315 45° BK	315	11.1	144

45° BRANCH

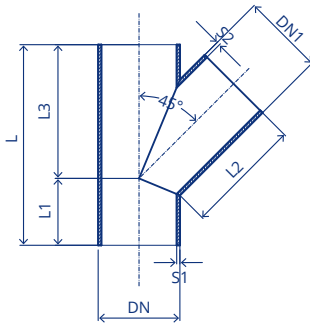

ARTICLE NUMBER	PRODUCT DESCRIPTION	DN / DN1 (mm)	S / S1 (mm)	L (mm)	L1 (mm)	L2 (mm)	L3 (mm)
1533000544	PE80 SIPH ROOF BRANCH 50 45° BK	50	3	157	52	110	105
1533000545	PE80 SIPH ROOF BRANCH 56 45° BK	56	3	162	58	108	104
1533000546	PE80 SIPH ROOF BRANCH 63 45° BK	63	3	188	65	128	123
1533000547	PE80 SIPH ROOF BRANCH 75 45° BK	75	3	199	62	142	137
1533000548	PE80 SIPH ROOF BRANCH 90 45° BK	90	3.5	245	80	176	165
1533000549	PE80 SIPH ROOF BRANCH 110 45° BK	110	4.3	255	73	183	182
1533000550	PE80 SIPH ROOF BRANCH 125 45° BK	125	4.9	312	87	226	225
1533000551	PE80 SIPH ROOF BRANCH 160 45° BK	160	6.2	330	86	247	244
1533000552	PE80 SIPH ROOF BRANCH 200 45° BK	200	6.2	485	89	396	395
1533000553	PE80 SIPH ROOF BRANCH 250 45° BK	250	7.8	575	96	479	478
1533000554	PE80 SIPH ROOF BRANCH 315 45° BK	315	9.8	726	112	614	613

45° Y TEE BRANCH

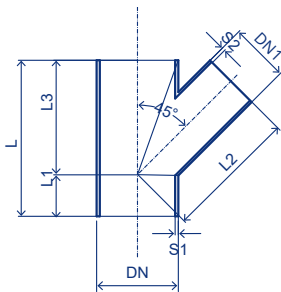

ARTICLE NUMBER	PRODUCT DESCRIPTION	DN / DN1 (mm)	S (mm)	S1 (mm)	L (mm)	L1 (mm)	L2 (mm)	L3 (mm)
1533000555	PE80 SIPH ROOF BRANCH 63-50 45° BK	63/50	3	3	151	58	105	154
1533000556	PE80 SIPH ROOF BRANCH 90-75 45° BK	90/75	3.5	3	226	72	170	117
1533000557	PE80 SIPH ROOF BRANCH 75-50 45° BK	75/50	3	3	164	47	130	140
1533000558	PE80 SIPH ROOF BRANCH 75-63 45° BK	75/63	3	3	195	55	148	126
1533000559	PE80 SIPH ROOF BRANCH 90-50 45° BK	90/50	3.5	3	176	50	142	144
1533000560	PE80 SIPH ROOF BRANCH 90-63 45° BK	90/63	3.5	3	194	50	166	156
1533000561	PE80 SIPH ROOF BRANCH 110-63 45° BK	110/63	4.3	3	204	58	162	146
1533000562	PE80 SIPH ROOF BRANCH 110-75 45° BK	110/75	4.3	3	210	54	170	156
1533000563	PE80 SIPH ROOF BRANCH 110-90 45° BK	110/90	4.3	3.5	256	75	195	181
1533000564	PE80 SIPH ROOF BRANCH 125-75 45° BK	125/75	4.9	3.5	237	65	190	172
1533000565	PE80 SIPH ROOF BRANCH 125-90 45° BK	125/90	4.9	4.3	268	78	205	190
1533000565	PE80 SIPH ROOF BRANCH 125-110 45° BK	125/110	4.9	4.3	268	75	223	204
1533000567	PE80 SIPH ROOF BRANCH 160-110 45° BK	160/110	6.2	4.3	279	70	225	195
1533000568	PE80 SIPH ROOF BRANCH 160-125 45° BK	160/125	6.2	4.9	265	78	245	231
1533000569	PE80 SIPH ROOF BRANCH 200-110 45° BK	200/110	6.2	4.3	309	87	265	223
1533000570	PE80 SIPH ROOF BRANCH 200-125 45° BK	200/125	6.2	4.9	310	70	270	231
1533000571	PE80 SIPH ROOF BRANCH 200-160 45° BK	200/160	6.2	6.2	301	72	315	305
1533000572	PE80 SIPH ROOF BRANCH 250-110 45° BK	250/110	7.8	4.3	377	68	295	241
1533000573	PE80 SIPH ROOF BRANCH 250-125 45° BK	250/125	7.8	4.9	309	65	287	245
1533000574	PE80 SIPH ROOF BRANCH 250-160 45° BK	250/160	7.8	6.2	310	70	322	283
1533000575	PE80 SIPH ROOF BRANCH 315-110 45° BK	315/110	9.8	4.3	318	50	323	268
1533000576	PE80 SIPH ROOF BRANCH 315-125 45° BK	315/125	9.8	4.9	367	80	328	287
1533000577	PE80 SIPH ROOF BRANCH 315-160 45° BK	315/160	9.8	6.2	367	70	340	297

EXCENTRIC REDUCER

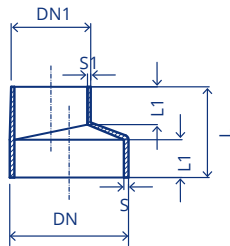

ARTICLE NUMBER	PRODUCT DESCRIPTION	DN/ DN1 (mm)	S (mm)	S1 (mm)	L (mm)	L1 (mm)	L2 (mm)
1533000596	PE80 SIPH ROOF REDUCER 56-50 BK EXC	56/50	3	3	78	36	37
1533000597	PE80 SIPH ROOF REDUCER 63-50 BK EXC	63/50	3	3	83	34	34
1533000598	PE80 SIPH ROOF REDUCER 63-56 BK EXC	63/56	3	3	83	33	35
1533000599	PE80 SIPH ROOF REDUCER 75-50 BK EXC	75/50	3	3	79	34	34
1533000600	PE80 SIPH ROOF REDUCER 75-56 BK EXC	75/56	3	3	83	33	35
1533000601	PE80 SIPH ROOF REDUCER 75-63 BK EXC	75/63	3	3	83	34	34
1533000602	PE80 SIPH ROOF REDUCER 90-50 BK EXC	90/50	3.5	3	83	33	34
1533000603	PE80 SIPH ROOF REDUCER 90-56 BK EXC	90/56	3.5	3	83	34	34
1533000604	PE80 SIPH ROOF REDUCER 90-63 BK EXC	90/63	3.5	3	83	33	34
1533000605	PE80 SIPH ROOF REDUCER 90-75 BK EXC	90/75	3.5	3	83	33	34
1533000606	PE80 SIPH ROOF REDUCER 110-50 BK EXC	110/50	4.3	3	83	34	34
1533000607	PE80 SIPH ROOF REDUCER 110-56 BK EXC	110/56	4.3	3	83	34	34
1533000608	PE80 SIPH ROOF REDUCER 110-63 BK EXC	110/63	4.3	3	83	34	34
1533000609	PE80 SIPH ROOF REDUCER 110-75 BK EXC	110/75	4.3	3	84	35	35
1533000610	PE80 SIPH ROOF REDUCER 110-90 BK EXC	110/90	4.3	3.5	83	34	34
1533000650	PE80 SIPH ROOF REDUCER 125-50 BK EXC	125/50	4.9	3	84	34	34
1533000651	PE80 SIPH ROOF REDUCER 125-56 BK EXC	125/56	4.9	3	84	34	34
1533000611	PE80 SIPH ROOF REDUCER 125-63 BK EXC	125/63	4.9	3	84	34	34
1533000612	PE80 SIPH ROOF REDUCER 125-75 BK EXC	125/75	4.9	3	84	33	33
1533000613	PE80 SIPH ROOF REDUCER 125-90 BK EXC	125/90	4.9	3.5	82	33	34
1533000614	PE80 SIPH ROOF REDUCER 125-110 BK EXC	125/110	4.9	3.5	82	34	34
1533000652	PE80 SIPH ROOF REDUCER 160-75 BK EXC	160/75	6.2	4.3	83	34	34
1533000653	PE80 SIPH ROOF REDUCER 160-90 BK EXC	160/90	6.2	4.3	83	34	34
1533000615	PE80 SIPH ROOF REDUCER 160-110 BK EXC	160/110	6.2	4.3	83	34	34
1533000616	PE80 SIPH ROOF REDUCER 160-125 BK EXC	160/125	6.2	4.9	83	36	34
1533000658	PE80 SIPH ROOF REDUCER 200-90 BK EXC	200/90	7.7	3.5	156	76	60
1533000617	PE80 SIPH ROOF REDUCER 200-110 BK EXC	200/110	7.7	4.3	156	76	60
1533000618	PE80 SIPH ROOF REDUCER 200-125 BK EXC	200/125	7.7	4.9	156	76	64
1533000619	PE80 SIPH ROOF REDUCER 200-160 BK EXC	200/160	7.7	6.2	156	76	62
1533000654	PE80 SIPH ROOF REDUCER 250-110 BK EXC	250/110	9.6	4.3	154	78	60
1533000655	PE80 SIPH ROOF REDUCER 250-125 BK EXC	250/125	9.6	4.9	154	78	60
1533000656	PE80 SIPH ROOF REDUCER 250-160 BK EXC	250/160	9.6	6.2	154	79	60
1533000620	PE80 SIPH ROOF REDUCER 250-200 BK EXC	250/200	9.6	7.7	154	79	60
1533000657	PE80 SIPH ROOF REDUCER 315-160 BK EXC	315/160	12.1	6.2	158	79	62
1533000621	PE80 SIPH ROOF REDUCER 315-200 BK EXC	315/200	12.1	7.7	158	79	62
1533000622	PE80 SIPH ROOF REDUCER 315-250 BK EXC	315/250	12.1	9.6	161	79	67

EXPANSION SOCKET

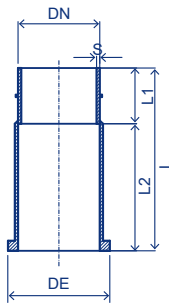

ARTICLE NUMBER	PRODUCT DESCRIPTION	DN/ DN1 (mm)	S (mm)	S1 (mm)	L (mm)	L1 (mm)	L2 (mm)
1533000578	PE80 SIPH ROOF L-SOCKET 50 BK	50	3	77	203	45	158
1533000579	PE80 SIPH ROOF L-SOCKET 75 BK	75	3	100	223	44	179
1533000580	PE80 SIPH ROOF L-SOCKET 90 BK	90	3.5	128	234	45	189
1533000581	PE80 SIPH ROOF L-SOCKET 110 BK	110	4.3	137	246	75	171
1533000582	PE80 SIPH ROOF L-SOCKET 125 BK	125	4.9	180	240	52	188
1533000583	PE80 SIPH ROOF L-SOCKET 160 BK	160	6.2	180	265	75	190
1533000584	PE80 SIPH ROOF L-SOCKET 200 BK	200	6.2	245	250	53	197

ELECTROFUSION SLEEVE COUPLING

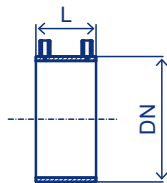

ARTICLE NUMBER	PRODUCT DESCRIPTION	DN (mm)	L (mm)
1533000585	PE80 SIPH ROOF COUPLER 50 BK EF	50	68
1533000586	PE80 SIPH ROOF COUPLER 56 BK EF	56	67
1533000587	PE80 SIPH ROOF COUPLER 63 BK EF	63	67
1533000588	PE80 SIPH ROOF COUPLER 75 BK EF	75	67
1533000589	PE80 SIPH ROOF COUPLER 90 BK EF	90	66
1533000590	PE80 SIPH ROOF COUPLER 110 BK EF	110	74.5
1533000591	PE80 SIPH ROOF COUPLER 125 BK EF	125	67
1533000592	PE80 SIPH ROOF COUPLER 160 BK EF	160	74
1533000593	PE80 SIPH ROOF COUPLER 200 BK EF	200	83
1533000594	PE80 SIPH ROOF COUPLER 250 BK EF	250	123
1533000595	PE80 SIPH ROOF COUPLER 315 BK EF	315	143

ACCESSORIES

SIMPLE POINT CLAMP

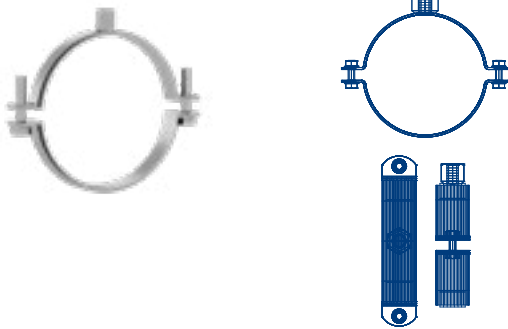

ARTICLE NUMBER	PRODUCT DESCRIPTION	CLAMPING RANGE (mm)
1533000659	Steel Clamp 1¼" M8 NUT	36-43
1533000660	Steel Clamp 1½" M8 NUT	44-50
1533000661	Steel Clamp 2" M8 NUT	60-65
1533000662	Steel Clamp 64-71 M8 NUT	64-71
1533000663	Steel Clamp 2½" M10 NUT	75-84
1533000664	Steel Clamp 3½" M10 NUT	94-104
1533000665	Steel Clamp 4" M10 NUT	109-119
1533000666	Steel Clamp 4½" M10 NUT	118-125
1533000667	Steel Clamp 5½" M10 NUT	150-162
1533000668	Steel Clamp 7" M10 NUT	197-207
1533000669	Steel Clamp 10" M10 NUT	269-275

FIXED POINT CLAMP

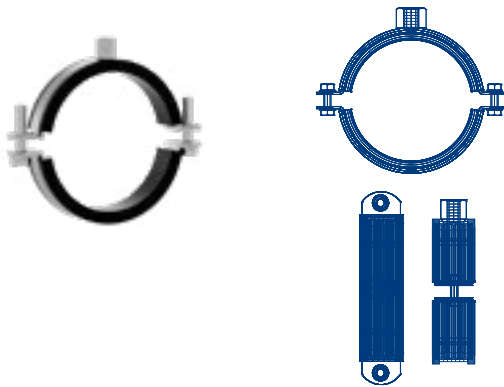

ARTICLE NUMBER	PRODUCT DESCRIPTION	CLAMPING RANGE (mm)
1533000685	Steel Clamp 1¼" M8 NUT/RUBBER	40-46
1533000686	Steel Clamp 1½" M8 NUT/RUBBER	48-53
1533000687	Steel Clamp 2" M8 NUT/RUBBER	60-66
1533000688	Steel Clamp 64-71 M8 NUT/RUBBER	64-71
1533000689	Steel Clamp 2½" M10 NUT/RUBBER	75-84
1533000690	Steel Clamp 3½" M10 NUT/RUBBER	94-104
1533000691	Steel Clamp 4" M10 NUT/RUBBER	109-119
1533000692	Steel Clamp 4½" M10 NUT/RUBBER	118-125
1533000693	Steel Clamp 5½" M10 NUT/RUBBER	150-162
1533000694	Steel Clamp 7" M10 NUT/RUBBER	197-207
1533000695	Steel Clamp 10" M10 NUT/RUBBER	269-275

SLIDE NUT



ARTICLE NUMBER	PRODUCT DESCRIPTION	CLAMPING RANGE (mm)	WASHER (Outer Diameter x Thickness)
1533000670	Steel Slide nut TB5 M8 L40	40	32 x 2.00 mm
1533000671	Steel Slide nut TB5 M8 L50	50	32 x 2.00 mm
1533000672	Steel Slide nut TB5 M10 L40	40	32 x 2.00 mm
1533000673	Steel Slide nut TB5 M10 L60	60	32 x 2.00 mm

C PROFILE

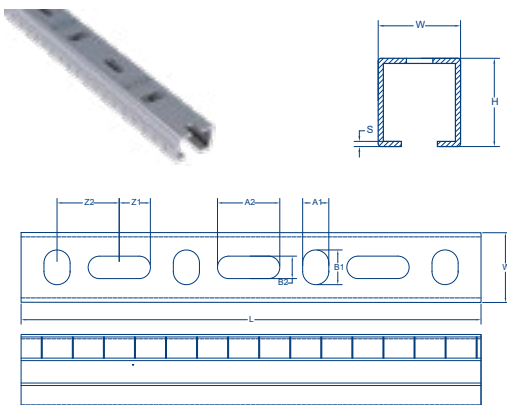

ARTICLE NUMBER	DESCRIPTION OF THE PRODUCT	W (mm)	H (mm)	L (mm)	S (mm)	Z (mm)	A1XB1 (mm)	A2XB2 (mm)	Z1XZ2 (mm)
1533000674	Steel C-Profile 28x30x4000 1.75mm	28	30	4000	1.75	14	14 x 10.5	25 x 9	12.5 x 25
1533000675	Steel C-Profile 38x40x4000 2.00mm	38	40	4000	2	16.5	12.5 x 16	25 x 9	12.5 x 25

THREADED ROD



ARTICLE NUMBER	DESCRIPTION OF THE PRODUCT	SIZE M	LENGHT L (mm)
1533000677	Steel ROD M10 L1000	M10	1000

U-SHAPED WASHER

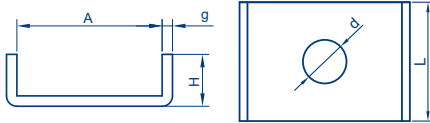

ARTICLE NUMBER	DESCRIPTION OF THE PRODUCT	d (mm)	A (mm)	H (mm)	L (mm)	g (mm)
1533000678	Steel Washer M10 27x18 U-Shape	9	28	10	30	2
1533000679	Steel Washer M10 38x40 U-Shape	11	39	12	30	2

WIDE WASHER

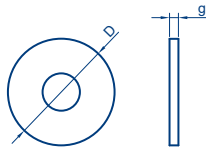

ARTICLE NUMBER	DESCRIPTION OF THE PRODUCT	INNER DIAMETER D (mm)	OUTTER DIAMETER D (mm)	THICKNESS g (mm)
1533000680	Steel Washer M10 wide	10.5	30	2.5

NUT

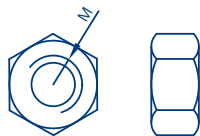

ARTICLE NUMBER	DESCRIPTION OF THE PRODUCT	SIZE M
1533000681	Steel Nut M8	M8
1533000682	Steel Nut M10	M10

BOLT

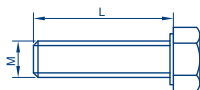

ARTICLE NUMBER	DESCRIPTION OF THE PRODUCT	SIZE M	LENGTH L (mm)
1533000683	Steel Bolt M8 L100	M8	30

V-TRAPEZE HANGER

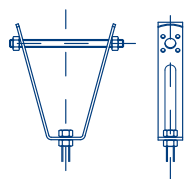

ARTICLE NUMBER	DESCRIPTION OF THE PRODUCT	SIZE M
1533000684	Steel Trapezoid Hanger M10	M10



The contents and information contained in this brochure are intended for general marketing purposes only and shall not be relied upon by any person as complete or accurate. In particular, this brochure cannot replace proper expert advice on the characteristics of the products, their usage, suitability for any intended purpose, or the proper processing method. All contributions and illustrations in this brochure are subject to copyright. Unless explicitly otherwise stated, the repetition of content is not permitted. The use of photocopies from this brochure is for private and non-commercial use only. Any duplication or distribution for professional purposes is strictly forbidden. Non-Liability: PIPELIFE has established this brochure to the best of its knowledge. PIPELIFE cannot accept any liability suffered or incurred by any person resulting from or in connection with any reliance on the content of or the information contained in this brochure. This limitation applies to all loss or damage of any kind, including but not limited to direct or indirect damages, consequential or punitive damages, frustrated expenses, lost profit or loss of business.

Date issued: February 2024

PIPELIFE International GmbH, Wienerbergerplatz 1, 1100 Wien
T +43 1 602 2030 0, E info@pipelife.com, pipelife.com

PIPELIFE 
always part of your life